

TOP VIEW

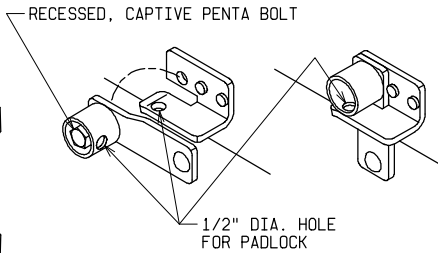

LATCH DETAIL

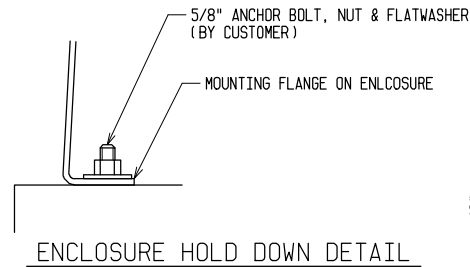

ENCLOSURE HOLD DOWN DETAIL

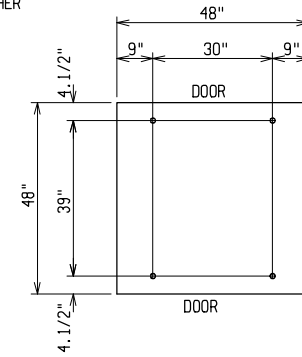

PAD AND ANCHOR BOLT DIMENSIONS

ANCHOR BOLTS TO BE 5/8" DIA. AND TO EXTEND 1.1/2" MINIMUM ABOVE PAD. PROVIDE CABLE ENTRY AS REQUIRED.

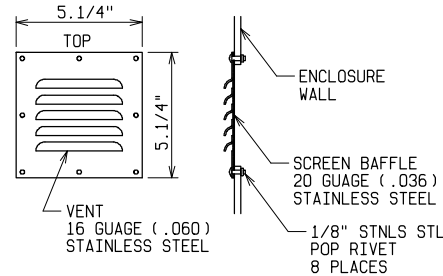

LOUVER DETAIL

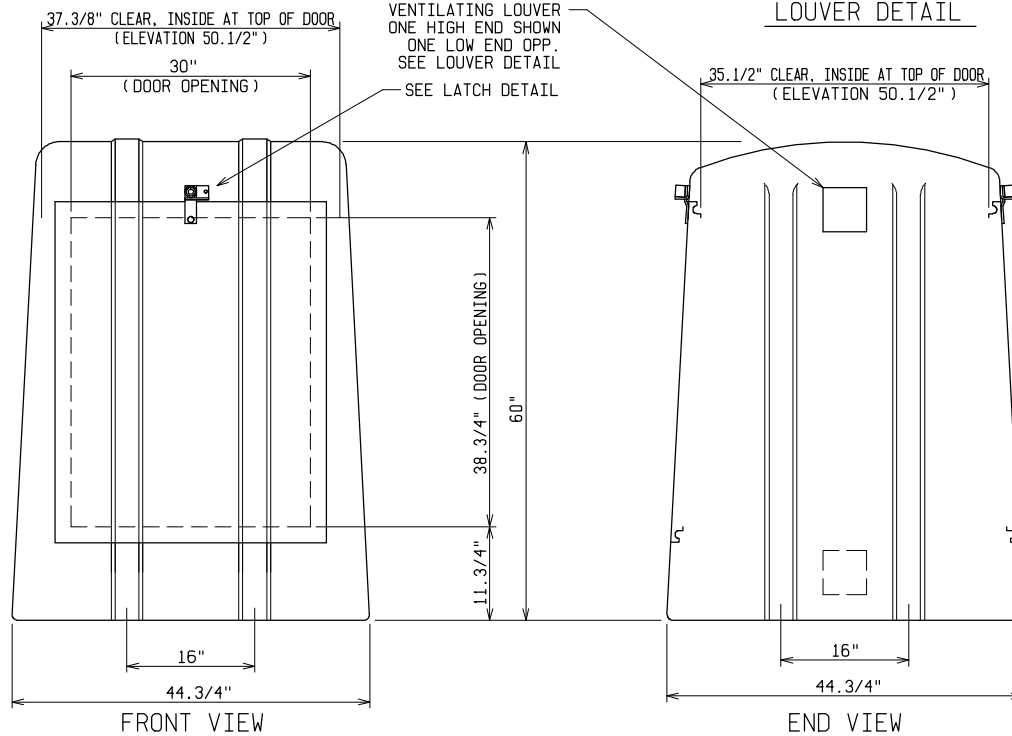

FRONT VIEW

END VIEW

ORDERING INFORMATION:

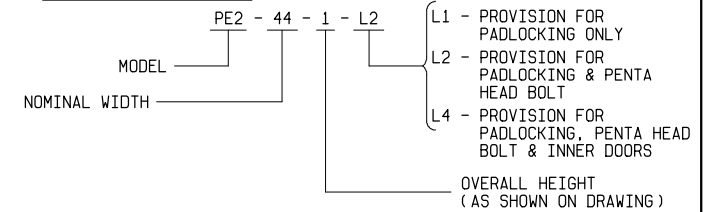

NOTE:

- MATERIAL:
 - FIBERGLASS LAMINATE 3/16" NOMINAL THICKNESS
 - EXTERIOR UV STABILIZED GELCOAT - 14 MIL NOMINAL THICKNESS
 - FIRE RETARDANT - DOES NOT SUPPORT COMBUSTION
 - STAINLESS STEEL HARDWARE
- STANDARDS:
 - CONFORMS TO ANSI C57.12.28, PADMOUNT EQUIPMENT ENCLOSURE INTEGRITY STANDARD
 - CERTIFIED TEST DATA OF ASTM STRUCTURAL STANDARDS AVAILABLE UPON REQUEST

ENCLOSURE DETAILS			
PE2-44-1			
ODELL, OREGON			
DRAWN: BB	PAGE	DATE 11-2-93	DRAWING NO. 1036 -R1

FILE REF.